

6 DEALER MANUAL FOR H620 (RM G040.250/350/500.DC)



CONTENT

6.1 Introduction	2	6.3 Drive Unit Installation	4
6.2 Specifications	3	6.3.1 List of Tools to be used	4
6.2.1 Outline and geometric size	3	6.3.2 Motor Installation	4
6.2.2 Surface	3	6.4 Maintenance	6
6.2.3 Storage Information	3		

6.1 INTRODUCTION



- **Product Model**

RM G040.250.DC

RM G040.350.DC

RM G040.500.DC

- **Scope**

i Applies only to electrically powered pedelecs developed or licensed by Bafang. It is suitable for city and trekking bikes, which have been developed for road use. The engine is not suitable for sport competitions.

- **Identification**

The following graphic, is the identification numbers of the product, which are shown on the housing:

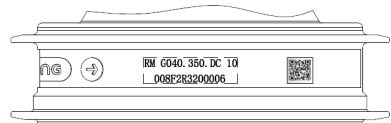

Note: Content in the label is important information about this product. Please do not remove the information from the motor.

6.2 SPECIFICATIONS

Motor model: RM G040.250.DC / RM G040.350.DC / RM G040.500.DC

Rated power (W)	250 / 350 / 500
Rated voltage (V)	36 / 43 / 48
Waterproof	IP65
Certification	CE / ROHS
Outdoor Temperatures	-20 °C~45 °C

6.2.1 Outline and geometric size

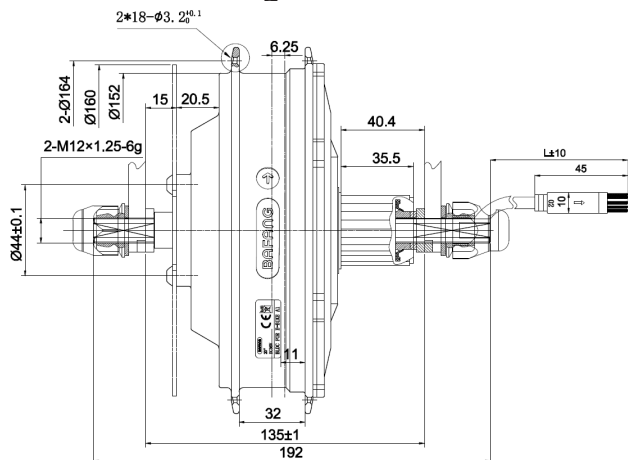

OLD: 135mm

Shaft length: 192mm

Motor cable length: L=250mm (optional)

6.2.2 Surface



Shockproof black and silver coating

6.2.3 Storage Information

The pedelec should be stored in a ventilated dry room. Avoid storing the pedelec near strong magnetic objects.

6.3 DRIVE UNIT INSTALLATION

6.3.1 List of Tools to be used

Use of the Tools	Tools
To tighten/loosen the M5*8 screws onto the disk brake.	 Internal hex wrench
To tighten/loosen the M12 flange nuts onto the frame.	 Open-end wrench

6.3.2 Motor Installation

1. First mount the disk brake onto the motor. Fasten disk brake with six M5*8 screws.
3. Mount a stop pin on both sides of the motor shaft.

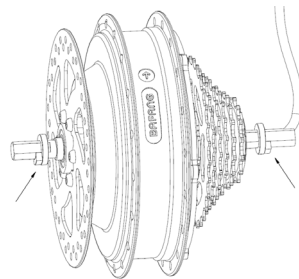
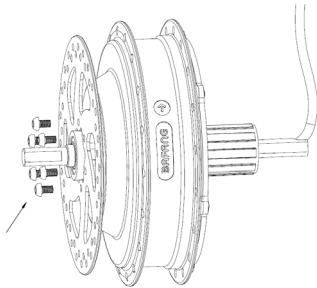

2. Mount the freewheel on the cassette.
4. Insert the motor into the frame.

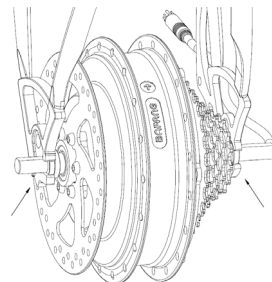
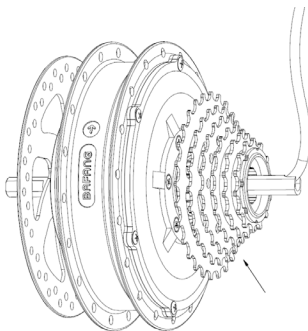

5. Insert a 2mm flat washer on both sides of the frame.

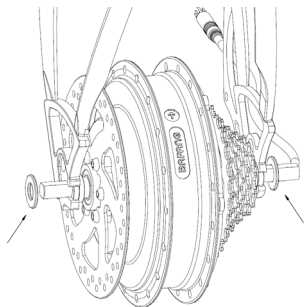

7. Mount the shaft end sheath on both sides of the shaft ends.

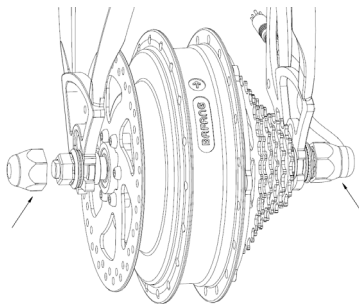

6. Fasten M12 flange nuts with open spanner at both sides of the motor. (torque requirement: 47-60N.m.)

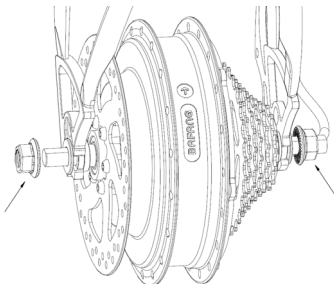

6.4 MAINTENANCE

- Maintenance must be carried out by authorized personnel with the correct equipment.
- Do not disassemble the motor.
- Do not use thinners or other solvents to clean the components. Such substances can damage the surfaces.
- Avoid water submerging, to keep the components protected.
- Avoid using high-pressure cleaning jets.
- For prolonged storage, turn off the battery and avoid storing near heat sources.